

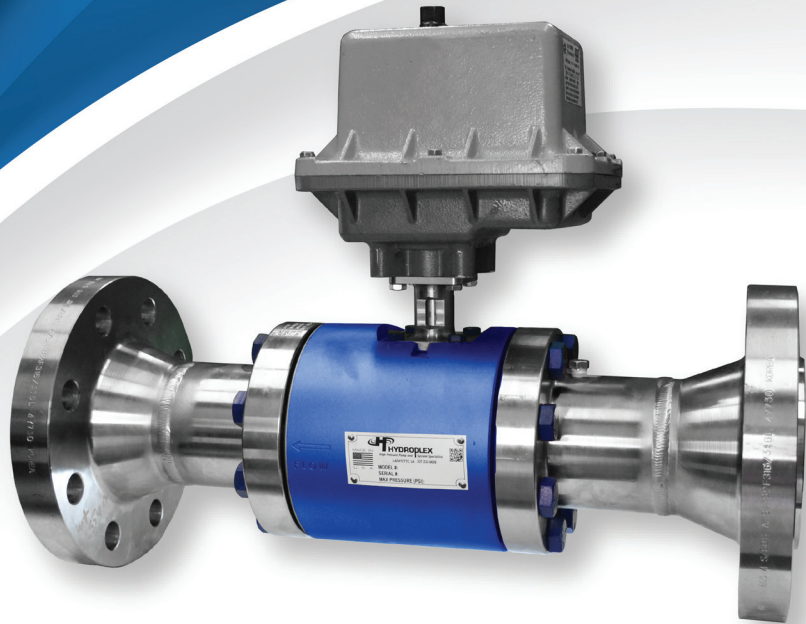

HYDRA SERIES Throttling Valves

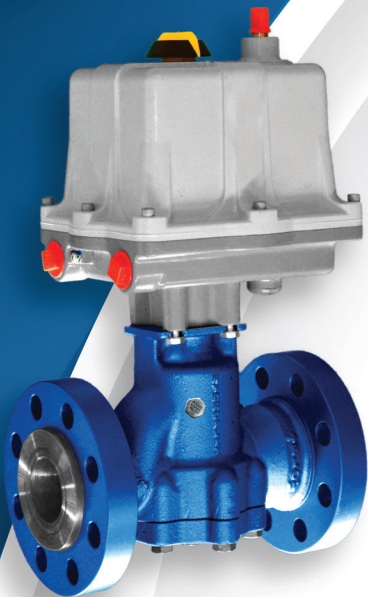

Patented Technology

Hydra Series

Adjustable Disc Throttling Valve

Hydroplex valves are quarter-turn twin disc throttling valves consisting of two diamond-polished concentric discs, each with two matching orifices. One disc is stationary in the valve and the other rotates to adjust the flow path. This unique trim is specifically designed for precision control of liquids and gases in severe service applications. The valve consists of minimal wear components and meets ANSI class IV shut off. These features result in an extremely durable design with easy field maintenance, increased service life, and reduced operational costs. The design flexibility allows field conversions from manual to automated under pressurized conditions. The patented multistage option allows this valve to handle extreme pressure drops and minimize freezing and/or cavitation. The twin discs and optional wear sleeve are abrasion resistant and direct the flow to the centerline of the piping which greatly extends the service life of the throttling valve.

PRINCIPLE OF OPERATION

Seal leakage classification for this product is an ANSI FCI 70-2 (ANSI B16.104) Class IV shutoff seal. The unique property of the twin disc format separates sealing surface from control surface and maintains a more reliable longer lasting seal.

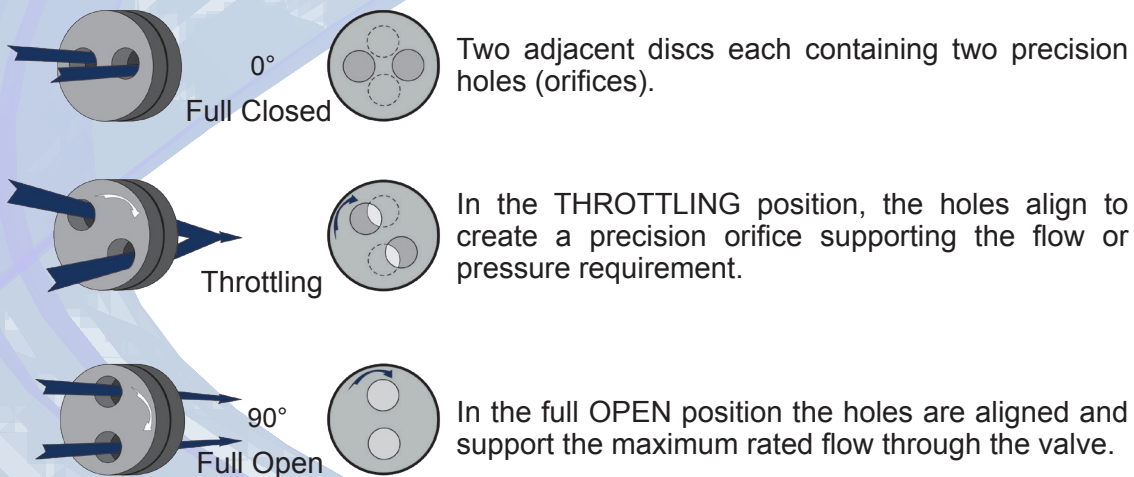

- The front disc floats against the back disc creating a mated interface and assures a positive seal.
- Differential pressure across the upstream disc promotes sealing, and stabilizes control surfaces.
- Discs are lapped to within two light-bands of flatness (.00002) to achieve a positive shut-off and maintain precise control.

Upstream disc floats allowing face to face alignment.

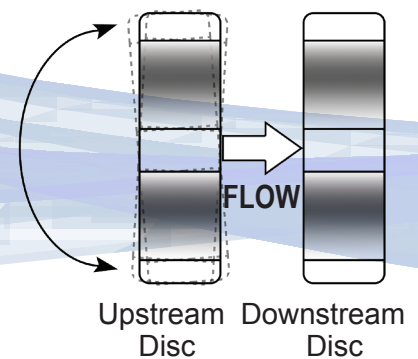

FEATURES

- Quarter turn valve (90 degrees full on/off)
- Direct Mount Actuation (HCI excluded)
- 5,000 psi MAWP / 3,000 psi MAWP for MiniMax
- Hardened wear sleeve for high pressure drops and abrasion.* (MiniMax excluded)
- Multistage DP system utilizing fixed orifice beans for multi-stage pressure drop.* (MiniMax Excluded)

* Optional Features

Patented Technology

APPLICATIONS

- Liquid & Gas Pressure or Flow Control
- Water & Gas Injection
- Gas Lift/Plunger Lift
- Manifold Pressure Control
- Gas & Condensate Production
- Separator Letdown / Dump
- Pump Start-up Bypass
- ESP / H-Pump Back-pressure Control
- Disposal Wells
- Reverse Osmosis

STANDARD MATERIALS OF CONSTRUCTION

- Body & Hubs
 - HCI/HCA/HCY - 316 SS (UNS S31600/ASTM A182)
 - CSX / MiniMax - WCB Carbon Steel
 - HydraMax - 316 SS or Carbon Steel
- Seals - Peroxide Cured Buna N 90D
- Disc - Tungsten Carbide with Nickel Binder
- Internals or Rotators - ANSI Type S17400 PH

TUNGSTEN CARBIDE TRIM OPTIONS

Orifices	Cv	64th inch Equiv. Dia.	Hole Geometry
2 ea. - 1/8"	0.74	11.3	Round
2 ea. - 3/16"	1.66	16.97	Round
2 ea. - 1/4"	2.95	22.6	Round
2 ea. - 3/8"	6.63	33.9	Round
2 ea. - 1/2"	11.78	45.3	Round
2 ea. - 3/4"	22.31	62.3	Pie

*See HydraMax on pg.5

Note: Generally, under high pressure drops, the valves would be set at:

Not less than 40% open for liquids.
Not less than 30% open for gas.

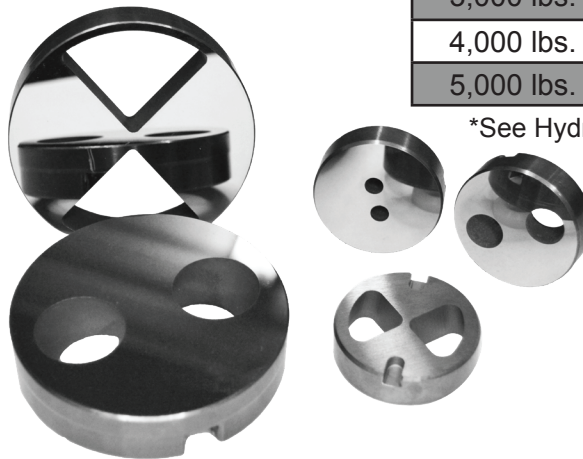

TORQUE RATINGS

Differential Pressure	Operating Torque
1,000 lbs.	160 in.-lb
2,000 lbs.	210 in.-lb
3,000 lbs.	270 in.-lb
4,000 lbs.	360 in.-lb
5,000 lbs.	480 in.-lb

*See HydraMax on pg. 5

UNIQUE SEGMENTED HUB DESIGN

The HCA, HCI, HCY, & HydraMax models feature our patented hub design.

This feature on the HCA, HCI, & HCY models consists of a unique locking wedge ring that provides greater sealing force and minimizes stress. Typically, throttling valves wear on the downstream side requiring a complete valve replacement. With our patented hub design, only the downstream hub would be exchanged, preserving the remainder of the valve. The HCA, HCY, & HydraMax bodies are ANSI Class 2500 regardless of end connection. To increase or decrease the pressure class of the valve, simply change out the hubs. For example, replacing both hub assemblies rated at ANSI Class 150 with assemblies rated Class 2500 will allow the product to be moved from MAWP 275 psi to a 5,000 psi working pressure.



Patented Technology

SEGMENTED VALVE COMPONENT DETAIL

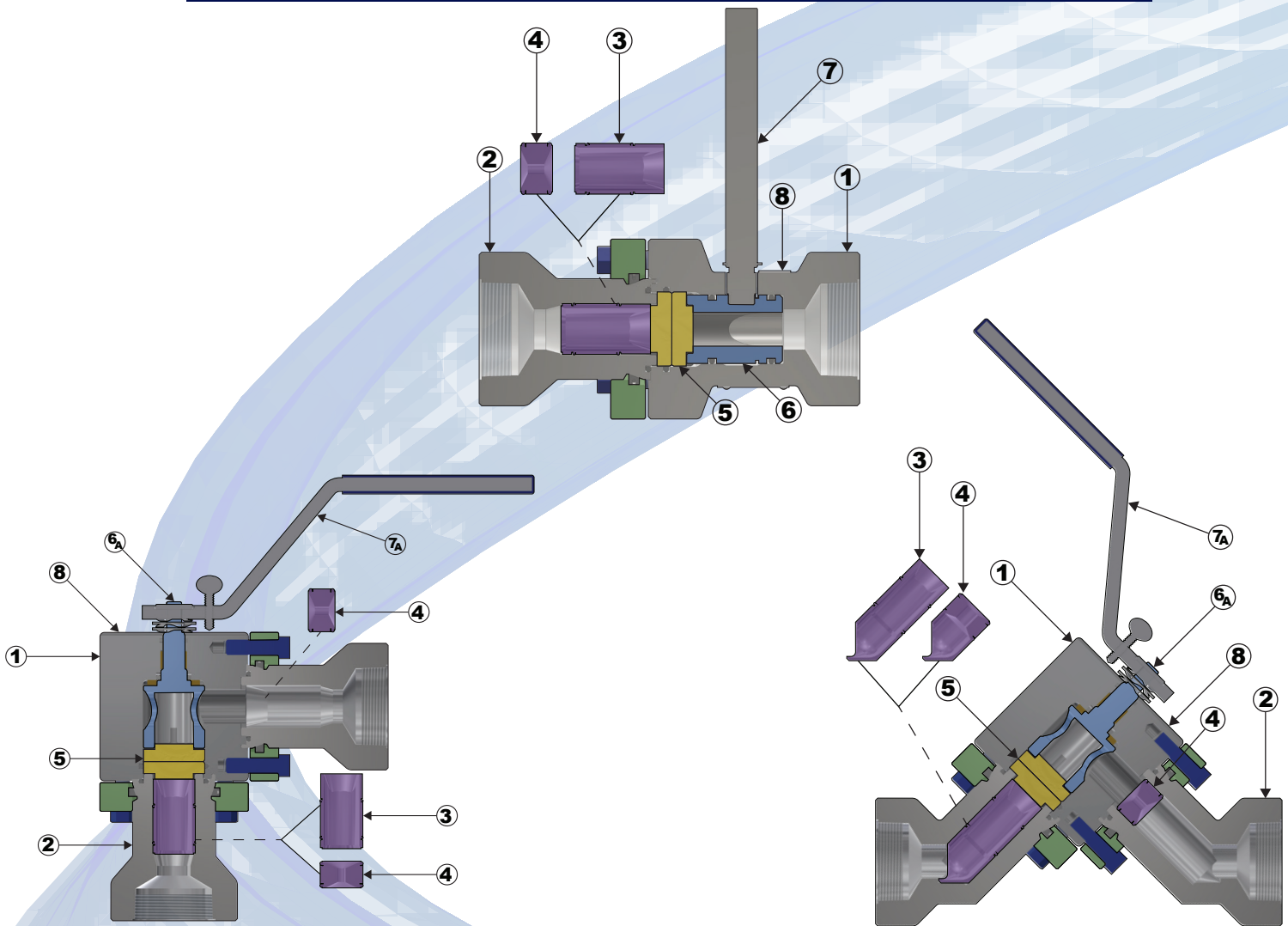

1. VALVE BODY: Durable and corrosion resistant 316 stainless material.

2. HUB ASSEMBLY: Allows easy access to internals without breaking pipe connections, disconnecting or recalibrating the actuator. The design allows for less expensive replacement of the downstream hub in lieu of replacing the whole valve body.

3. WEAR SLEEVE (OPTIONAL): All valve hubs allow for wear sleeves. The wear sleeve is made from a durable Stellite material for abrasive or turbulent environments extending valve life.

4. FIXED ORIFICE BEAN (OPTIONAL): The Hydra design allows for placement of a Fixed Orifice Bean to achieve up to a 2 (HCl) or 3 (HCA/HCY) stage pressure drop. It also extends the life of the valve.

5. TUNGSTEN CONTROL DISCS: All valves come standard with Tungsten carbide Trim available in sizes up to 3/4".

6. ROTATOR: The smaller rotator outside diameter reduces operating torque, requiring smaller and less expensive actuators.

6A. *STEM ASSEMBLY: The smaller shaft diameter reduces operating torque, requiring smaller and less expensive actuators.

7. MANUAL HANDLE: The handle and rotator are specifically designed to resist thread pullout.

7A. *MANUAL HANDLE (OPTIONAL): The thumb screw on the handle will resist movement of the stem until released.

8. CALIBRATION PLATE: Handle equipped with indicator pointing to a Calibration Plate showing percentage and # of 64ths open.

9. DIRECT ACTUATOR MOUNTING (NOT SHOWN): Design allows for mounting of common valve actuators with a simplified system to reduce hysteresis.

HCI, HCA & HCY THROTTLING VALVE MODELS

The HCI's simplified design lends itself easily to manual actuation, although it may be automated as the need arises. Because it uses our patented downstream hub, it can be fitted with a wear sleeve or a fixed orifice bean sized by Hydroplex engineering. The HCI uses a smaller rotator allowing for lower operating torques.

The HCA & HCY throttling valves provide a complete package for flow control. The direct mount capabilities reduce the risk of hysteresis while helping to protect the actuator shaft from the elements. The modular hub design allows the valve to handle large pressure drops utilizing our multistage system to include upstream and downstream fixed orifice beans.

END TO END DIMENSIONS

HCI, HCA, & HCY models are available in 3" flange. Consult factory for further information.

Size	Connection	HCI	HCA	HCY
1 in.	1FNPT	7.950	5.075	11.537
	150RF	11.623	7.225	14.421
	300RF	12.143	7.515	14.941
	400/600RF	12.643	7.765	15.441
	900/1500RF	13.523	8.205	16.321
	150RTJ	12.003	7.445	14.801
	300RTJ	12.523	7.705	15.321
	400/600RTJ	12.643	7.765	15.441
	900/1500RTJ	13.523	8.205	16.321
	Bevel for Weld	7.013	4.950	18.685
2 in.	2MNPT	7.950	5.075	11.537
	2FNPT	9.002	6.127	11.537
	150RF	12.263	7.575	15.061
	300RF	12.763	7.825	15.561
	400/600RF	11.253	7.070	14.049
	900/1500RF	15.765	9.326	18.563
	2500RF	17.763	10.325	20.561
	150RTJ	12.643	7.765	15.441
	300RTJ	13.267	8.077	16.065
	400/600RTJ	13.647	8.267	16.445
	900/1500RTJ	15.887	9.387	18.685
	2500RTJ	17.887	10.387	20.685
Bevel for Weld	7.013	4.950	9.811	

*Dimensions listed in inches.

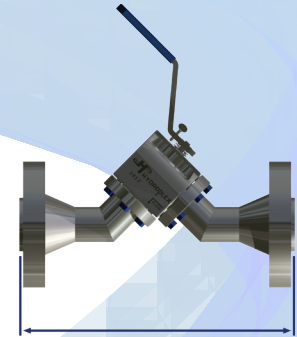
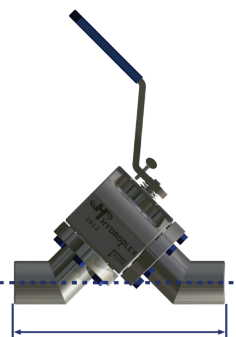
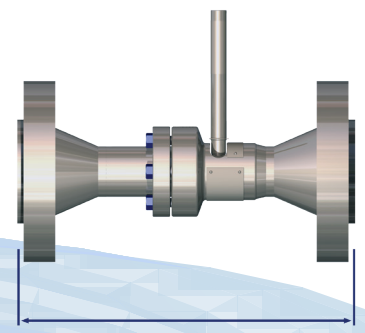
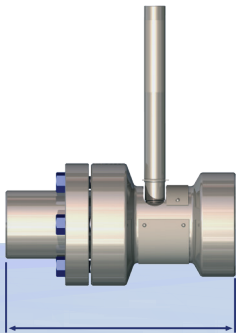
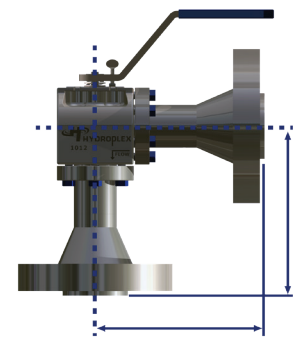
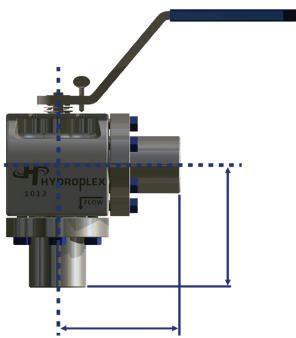

HYDRAMAX THROTTLING VALVE

TUNGSTEN CARBIDE TRIM OPTIONS

Orifices	Cv	64th inch Equiv. Dia.	Hole Geometry
2 ea. - 1"	48.79	92	Round
2 ea. - 1-1/4"	73.78	113	Pie
2 ea. - 1-3/8"	89.20	125	Pie

END TO END DIMENSIONS

Size	Connection	MAX	Size	Connection	MAX
3 in.	3FNPT	17.145	4 in.	Bevel For Weld	17.145
	Bevel For Weld	17.145		150RF	23.395
	150RF	22.895		300RF	24.155
	300RF	23.635		400RF	24.515
	600RF	24.395		600RF	25.895
	900RF	25.895		900RF	26.895
	1500RF	27.135		1500RF	27.655
	2500RF	31.135		2500RF	32.895
	150RTJ	23.275		150RTJ	23.775
	300RTJ	24.139		300RTJ	24.659
600RTJ	24.519	400RTJ	25.019		
900RTJ	26.019	600RTJ	26.019		
1500RTJ	27.259	900RTJ	27.019		
2500RTJ	31.385	1500RTJ	27.779		
			2500RTJ	33.271	

*Dimensions listed in inches.

OPERATING TORQUE

Differential Pressure	HydraMax
1,000 lbs.	600 in.-lb
2,000 lbs.	900 in.-lb
3,000 lbs.	1200 in.-lb
4,000 lbs.	1500 in.-lb
5,000 lbs.	1800 in.-lb

The ISO F07 pad allows for direct mount of common actuators. No need for additional couplings or brackets.

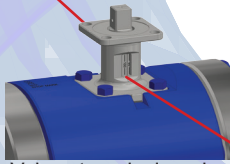

Valve stem designed with calibration marks indicating the percent of travel from 0 to 100.

Easily change from manual actuation to automated in the field without interrupting service.

Gears are isolated from the flow stream protecting them from unwanted contamination.

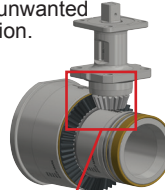

Wear Indication Monitoring Port

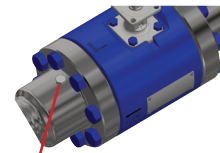

The optional hardened wear sleeve provides additional protection from abrasive flows and cavitation damage.

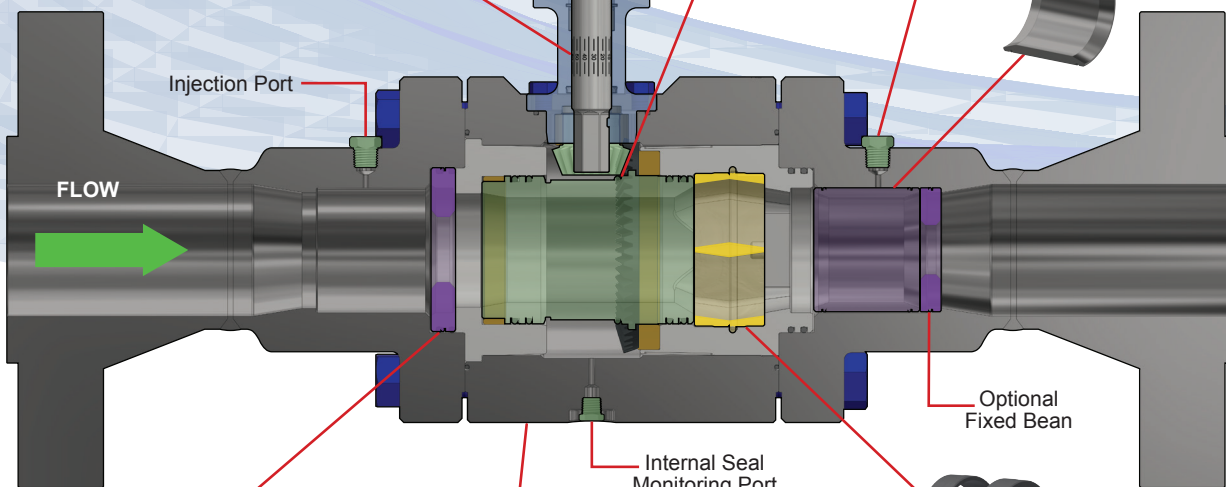
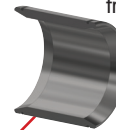

The hub design allows for the placement of optional fixed orifice beans to achieve a two or three stage pressure drop within the valve for severe service.

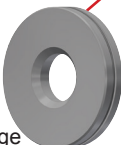

The exobody, while isolated from process fluids, is designed for pressure containment only. There is no contact with the flow stream.

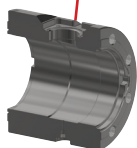

Twin disc control elements are available in a variety of sizes to accommodate flow and pressure requirements.

Patented Technology

OPTIONAL MULTISTAGE THROTTLING ASSEMBLY

Patented internal multistage pressure drop assemblies are recommended to reduce potential damage due to severe flow conditions. Hydroplex can engineer a multi-stage solution when accurate flow conditions are provided. This solution is primarily used in high pressure drop scenarios to reduce fluid velocity, which is a major factor in erosion, vibration, and excessive noise. Our engineered multistage valve can reduce cavitation and flashing in liquid service, as well as reduce freezing due to the Joule-Thomson effect in wet gas services.

Hydroplex is here to help size the trim for all conditions, especially in extreme applications where the pressure drop would exceed 50% of absolute upstream pressure. The images below show how multi-staging reduces the risk of damage. This is achieved by absorbing the pressure drop over multiple stages instead of the trim set only.

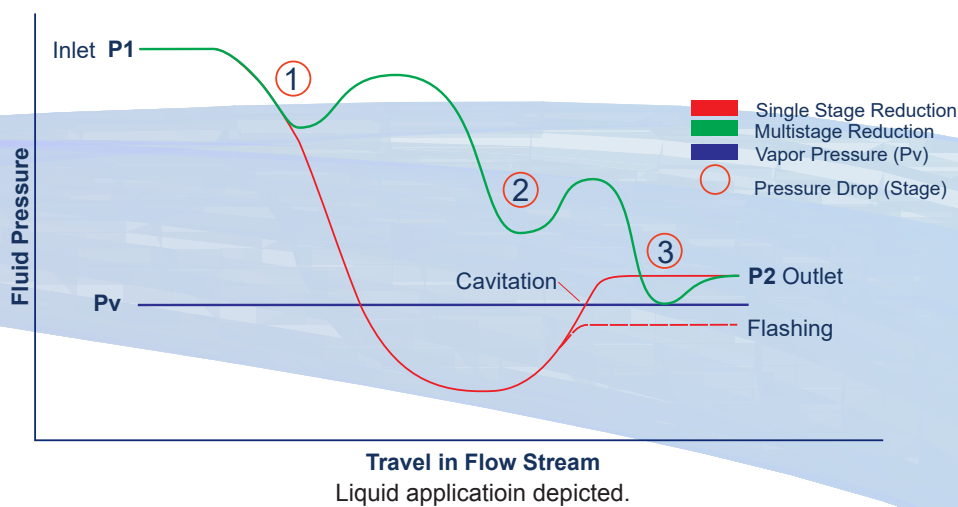
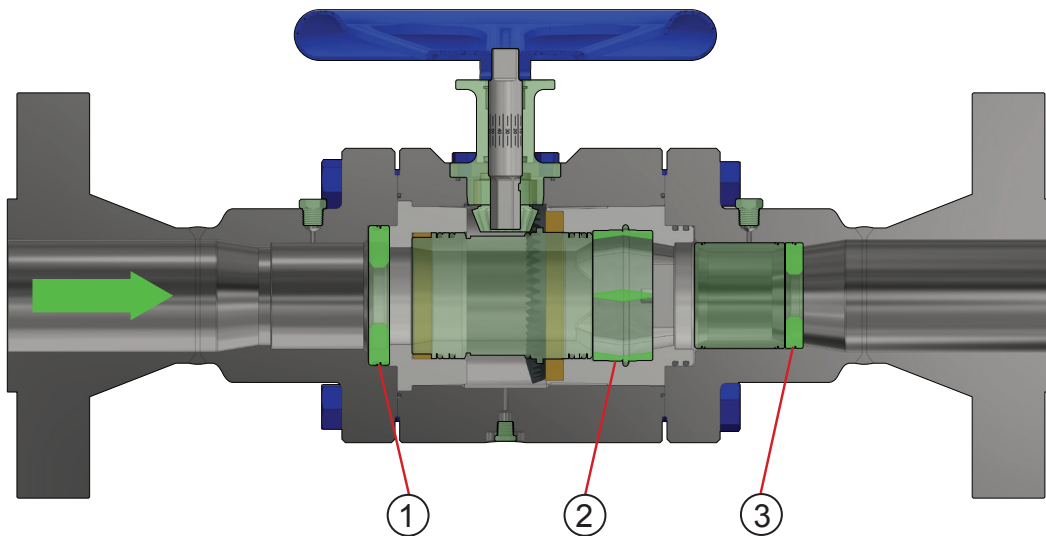

WaferMax Throttling Valve

The Hydroplex WaferMax is a versatile control valve that can be tailored to address sophisticated and simple pressure and flow requirements. Its Wafer construction requires minimum space for installation. The Inline flow path minimizes turbulence reducing erosion and increasing efficiency of the valve. The 3:1 gear ratio provides for precision control, while reducing torque and power requirement for automation. **The gear set is isolated from the fluid stream, preventing contact with contaminants and debris which could compromise the valve operation.**

All valve and trim components are designed to fit in place seamlessly, allowing for quick configuration to meet specific user process needs. The valve trim is fully guided and stable, minimizing vibration and mechanical noise. The free float design of the disc provides the user with enhanced and extended valve shut-off performance. The Twin Disc and Multistage system can help to better manage full pressure drops. The simplicity of the build also means that maintenance is quick and easy, with no special tools required to service the valve.

Hydroplex Engineered Solution

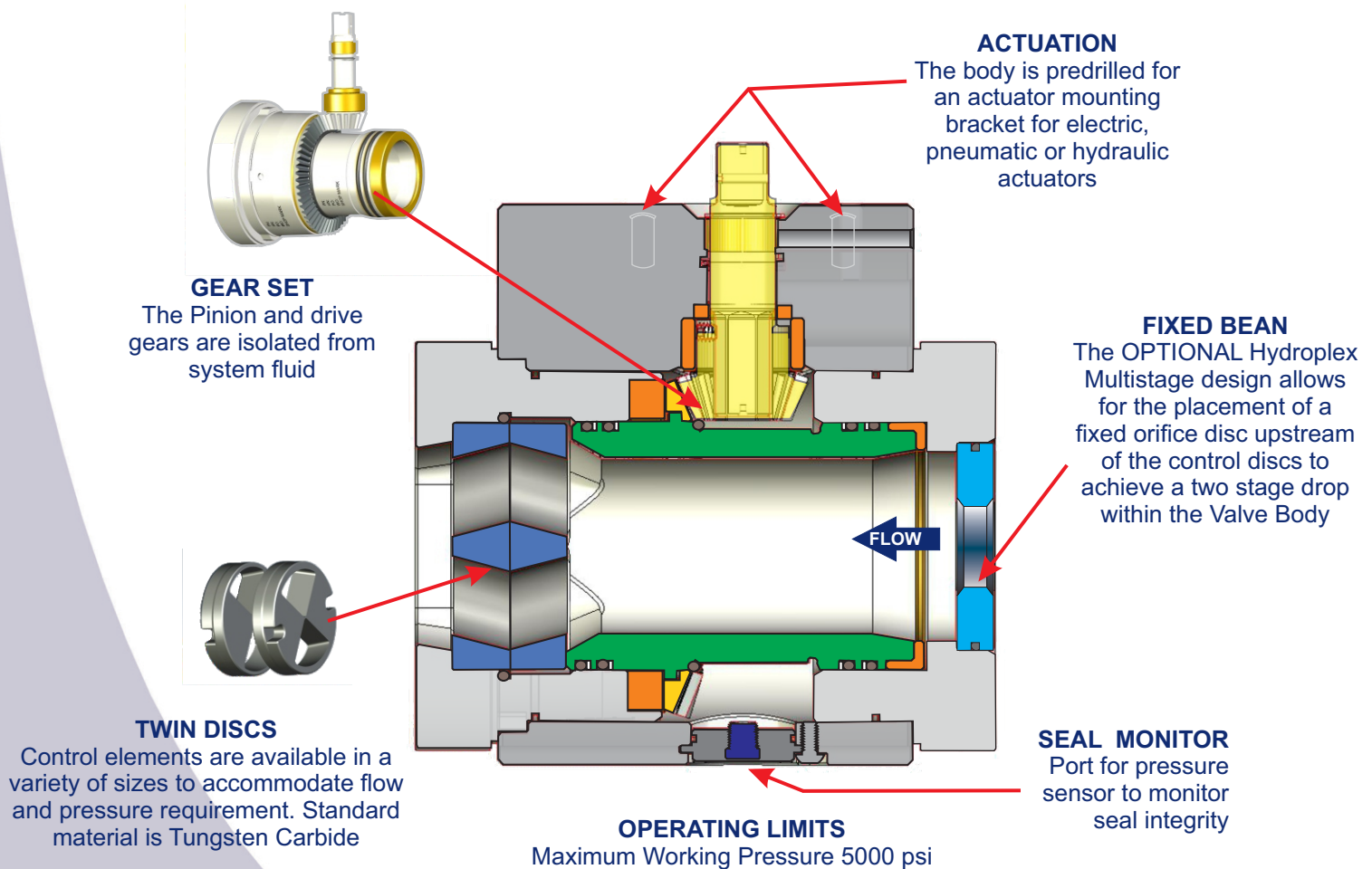

WaferMax Throttling Valve

Optional Features

Actuation: For control system integration.

Multistage Pressure Drop System:
Utilizing internal fixed orifice beans for high pressure control.

Dimensions

WaferMax can accommodate all ANSI or API 3" and 4" flanges.
For all raised face and RTJ flange types the face to face dimensions are 7.626 inches.

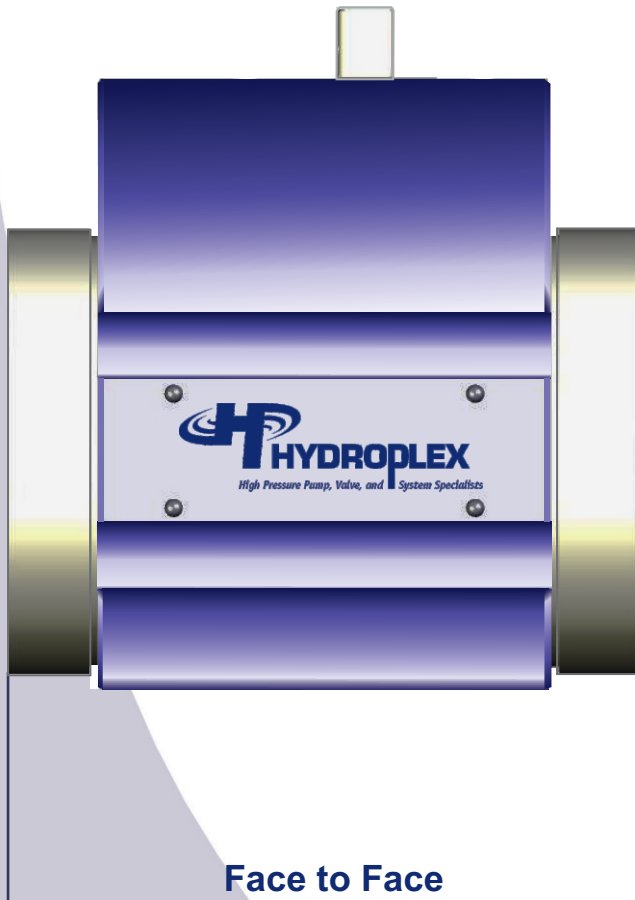

Wetted Component Standard** Materials

Description	Material
Body End Caps	316/316L Stainless Steel
Rotator	17- 4 PH H1150 Stainless Steel
Control Discs	Tungsten Carbide
Stem	17- 4 PH H900 Stainless Steel
Gear Set	High Alloy Steel
O-Rings	HNBR
Backup Rings	PTFE
Fix Bean*	17- 4 PH H900 Stainless Steel

* Optional

** For material other than Standard consult factory

Tungsten Carbide Trim Options

Orifice Size	Cv	64th inch Equiv. Dia.	Orifice Geometry
3.25 Inch Diameter Disc			
2 ea. - 1 3/8"	89.20	125	Pie
2 ea. - 1 1/4"	73.78	113	Pie
2 ea. - 1"	48.79	92	Round
1.75 Inch Diameter Disc			
2 ea. - 3/4"	27.14	62.3	Pie
2 ea. - 1/2"	11.78	45.3	Round
2 ea. - 3/8"	6.63	33.9	Round
2 ea. - 1/4"	2.95	22.6	Round
2 ea. - 3/16"	1.66	16.97	Round
2 ea. - 1/8"	0.74	11.3	Round

Applications

- Automated Well control
- Split Flow and Manifold Systems
- Salt Water Disposal
- Up or Downstream Set Point Control
- Pump Startup Bypass
- Electric Submersible Pump
- H Pump Back-pressure Control
- CO² Injection
- Process Control Valve

CSX THROTTLING VALVE

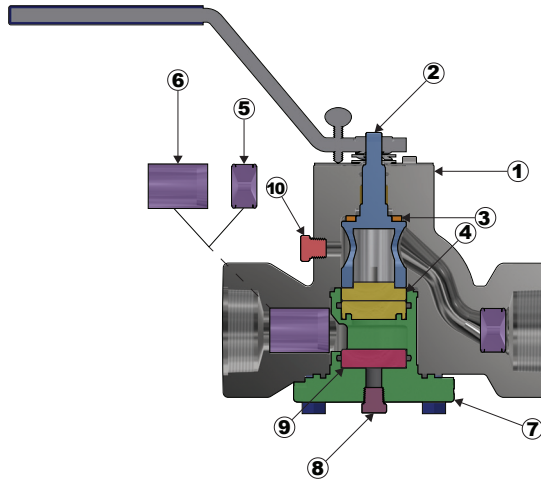

1. VALVE BODY: Durable carbon steel body.

2. STEM ASSEMBLY: The smaller shaft diameter reduces operating torque, requiring smaller and less expensive actuators.

3. THRUST BEARING: This reduces the friction induced by pressure on the valve stem.

4. TUNGSTEN CONTROL DISCS: All valves come standard with Tungsten carbide Trim available in sizes up to 3/4"

5. FIXED ORIFICE BEAN (OPTIONAL): The hub design allows for placement of a fixed orifice bean to achieve up to a 3 stage pressure drop within the valve The fixed orifice bean also extends the life of the valve.

6. WEAR SLEEVE (OPTIONAL): The downstream wear sleeve made of durable Stellite material, adds protection from abrasive or turbulent environments extending valve life.

7. CARTRIDGE ASSEMBLY: Holds in the wear components of the valve and allows for easy maintenance.

8. SCADA ACCESSIBLE SENSOR PORT: 1/4" threaded port to allow for installation of a pressure sensor or gauge or left open for leak detection.

9. WEAR DISC: This disc is meant to absorb energy from the change of direction of the fluid from the orifice discs to the valve outlet.

10. 1/4" NPT PORT: Access port for optional injection of liquids or gases for supplemental process improvements.

11. DIRECT ACTUATOR MOUNTING (NOT SHOWN): Design allows for direct mounting of several common valve actuators without the need for couplings or brackets.

CARTRIDGE ASSEMBLY

The CSX cartridge assembly allows for valve service and trim change in-place. Field service can be performed without removing the valve or valve/actuator assembly from the production line. The application of a pressure sensor/gauge in the 1/4" pressure port will notify the operator of pending maintenance requirements.

The most significant benefit of this design is that the valve body will not wear out under normal operating conditions. All potential wear components are contained in the cartridge, protecting the body from high velocity fluids and solids. The valve can be rebuilt to like new condition in the field.

END TO END DIMENSIONS

Consult factory for further information.

Size	Connection	CSX
1 in.	1FNPT	10.37
	2FNPT	8.625
2 in.	150RF	10.00
	400/600RF	9.750

*Dimensions listed in inches.

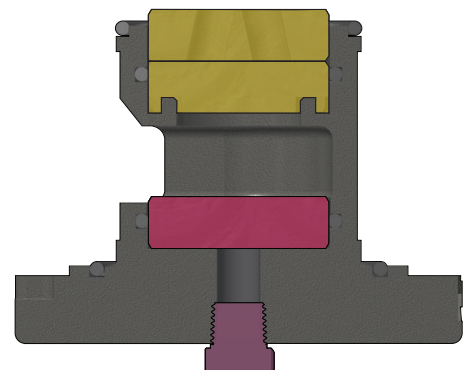

Patented Technology

MINIMAX CONVERTIBLE DUMP VALVE

Minimum footprint. Maximum performance.

The Hydroplex MiniMax Convertible Dump Valve is an excellent valve for use on all discharge ports of 2 and 3 phase separators as a quick dump or throttling valve for oil, gas, or water. The recommended maximum pressure drop (or differential pressure) in liquid service is 1500 psi for 90° angle configurations and 500 psi for in-line.

FEATURES

- Quarter turn valve (90 degrees full on/off)
- Direct mount actuation.
- Convertible Configuration: choose to plumb in-line or 90° right angle to fit your configuration.
- 3000 psi MAWP
- Rotary actuated - **NO LIFTER REQUIRED!**
- Control discs available in 6 sizes. See details on page 2.

OPERATING TORQUE

Differential Pressure	Operating Torque
1,000 lbs.	160 in.-lb
2,000 lbs.	210 in.-lb
3,000 lbs.	270 in.-lb

END TO END DIMENSIONS

Consult factory for further information.

Size	Connection	A	B	C
1 in.	FNPT	2.657	3.820	7.450
2 in.	FNPT	1.837	3.000	5.750

*Dimensions listed in inches.

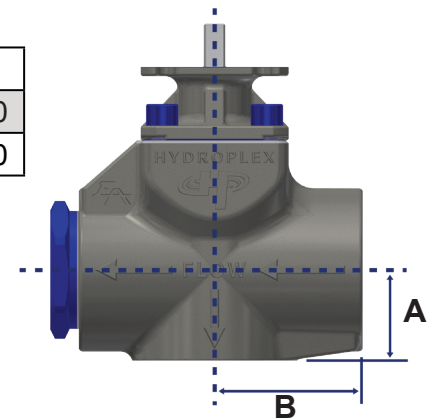
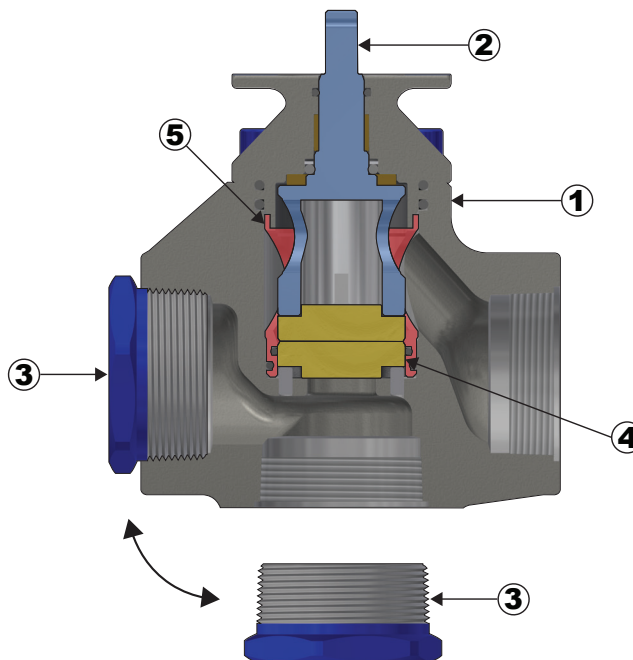
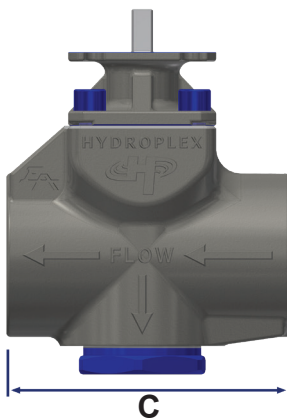

1. VALVE BODY: Durable carbon steel body.

2. STEM ASSEMBLY: The smaller shaft diameter reduces operating torque, requiring smaller and less expensive actuators.

3. CONVERTIBLE CONFIGURATION: With Hex Plug placement, choose to plumb in-line or 90° right angle to fit your configuration.

4. TUNGSTEN CONTROL DISCS: All valves come standard with Tungsten carbide Trim available in sizes up to 3/4".

5. ASSEMBLY CAGE: Allows for easy assembly and disassembly of all internal valve components.

6. DIRECT ACTUATOR MOUNTING (NOT SHOWN): Design allows for direct mounting of several common valve actuators without the need for couplings or brackets.

Patented Technology



TWIN DISC DUMP VALVE

an Environmentally Sound Solution compared to natural gas operated dump valves.

Electric or Pneumatically Actuated

Designed for very high open/close cycles in severe liquid applications, this valve can be internally staged to handle extreme pressure drops with the presence of solids requiring minimal maintenance. The low torque design reduces demand on solar powered systems. **When electrically actuated the valve releases ZERO emissions to atmosphere at rest and during operation.**



APPLICATIONS

- Discharge of liquid from:
- vessels,
 - separators,
 - treaters,
 - knockouts, and
 - other similar liquid accumulators.

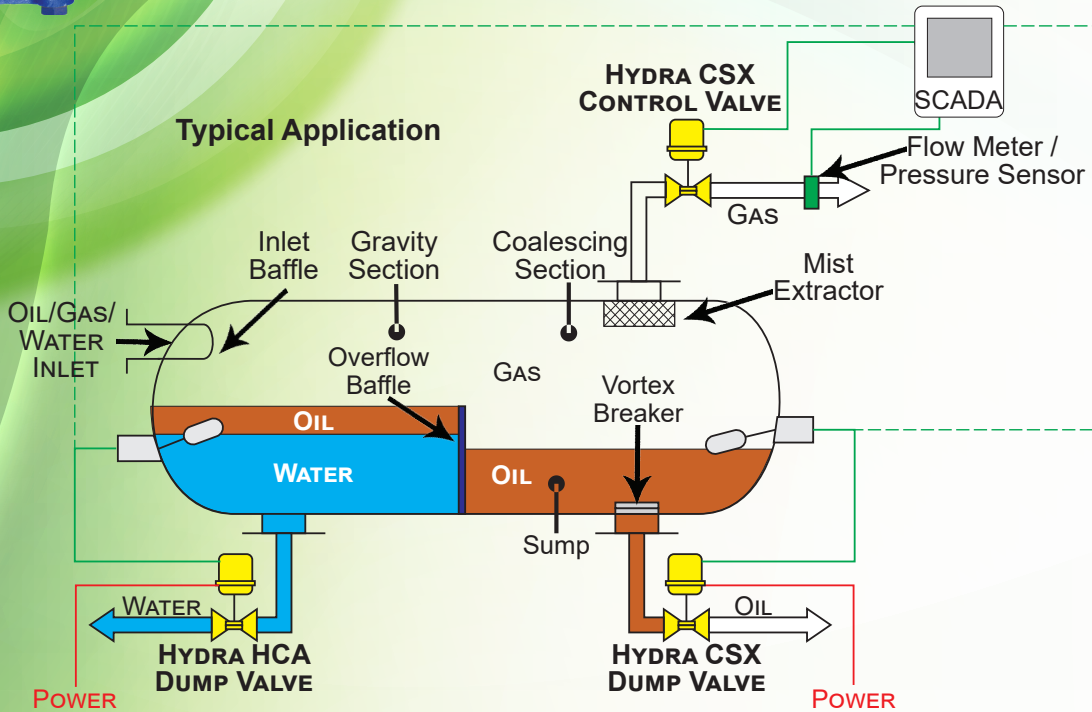

Patented Technology

TWIN DISC DUMP VALVE CONT.

Reduce your downtime and maintenance with the unique technology of the Hydroplex dump valve!

TUNGSTEN CARBIDE TRIM OPTIONS

Twin disc technology available in 6 sizes with Cv up to 22.

Hydroplex's patented in-valve multistage pressure drops can be added in abrasive applications on CSX & HCA. This engineered solution will reduce mechanical erosion and increase the lifespan of the valve.

ASSEMBLY DETAILS

- 316 Stainless Steel or Carbon Steel construction.
- 1" & 2" FNPT standard connections.
- Flanged connections available upon request.

TEMPERATURE RANGE

-20° to 325° F

WORKING PRESSURES

HCA - 5000 psig
CSX - 5000 psig
MiniMax - 3000 psig



ACTUATION

Electric

- Universal Power (AC/DC)
- Optional Battery Backup

Pneumatic

- Quick Open/Close

QUAD "O" COMPLIANT

LOW MAINTENANCE

LOW POWER CONSUMPTION

Patented Technology

ALSO AVAILABLE FROM HYDROPLEX

Complete injection systems for Enhanced Oil Recovery (EOR) to customer specifications.

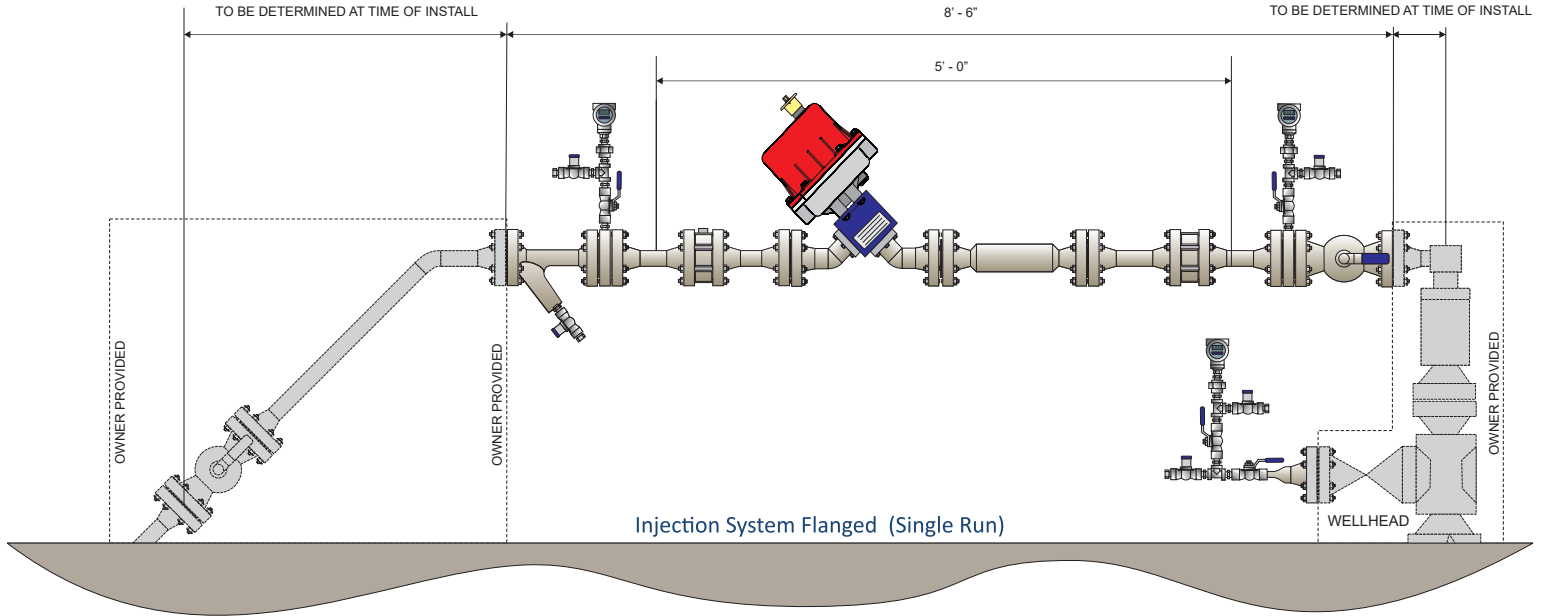

High Pressure Test Units



High Pressure Regulators

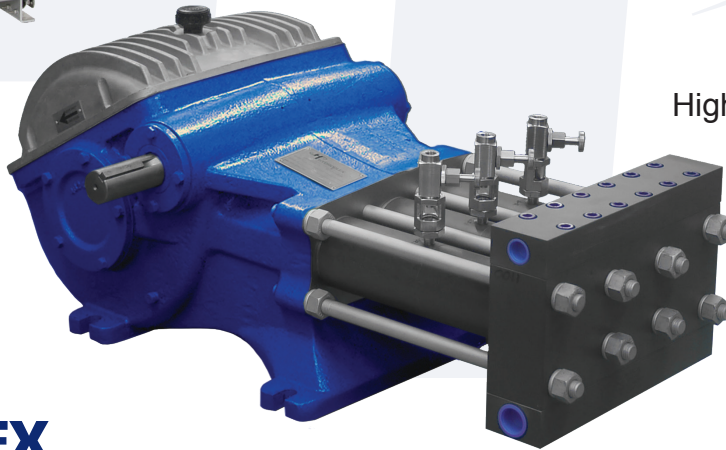

High Pressure Triplex Pumps



Hydroplex Corporation
230 W. Gloria Switch Rd.
Lafayette, LA 70507
337-233-0626
www.hydroplexpumps.com

Distributed By:

